

# SMART Board™ Interactive Whiteboard

## Specifications – Model V280

### Physical Specifications

<b>Size</b>	64" W x 53 1/8" H x 4" D (162.4 cm x 134.9 cm x 10.1 cm)
<b>Active Screen Area</b> (maximum interactive, projected image)	61 3/8" W x 46 1/8" H (155.9 cm x 117.2 cm) 76 7/8" diagonal (195.2 cm)
<b>Weight</b>	30 lb. (13.6 kg)
<b>Shipping Weight</b>	
1 unit	70 lb. (31.8 kg)
8 units on pallet	585 lb. (265.4 kg)
<b>Shipping Size</b>	
1 unit	58 7/8" W x 74" H x 6 5/8" D (149.5 cm x 188.0 cm x 16.8 cm)
8 units on pallet	58 7/8" W x 78 1/2" H x 52 7/8" D (149.5 cm x 199.4 cm x 134.4 cm)

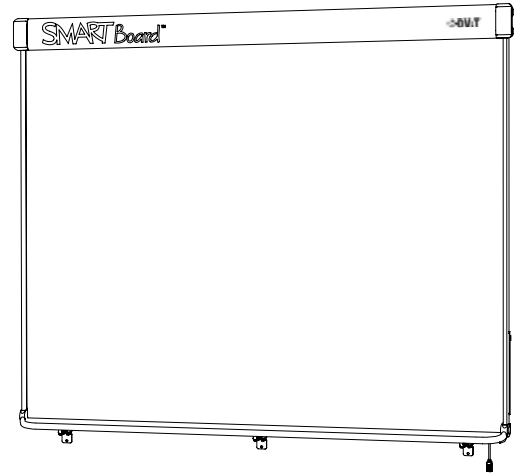

All dimensions +/- 1/8" (3.2 mm). All weights +/- 2 lb. (0.9 kg).

### Standard Features

<b>Software</b>	SMART Board™ software, including Notebook™ software. Software upgrades are available at <a href="http://www.smarttech.com/support/software/index.asp">www.smarttech.com/support/software/index.asp</a> .
<b>Pen Tray</b>	A simple, robust pen tray spans the entire width of the interactive whiteboard.
<b>Pens</b>	Two pens, each powered by one AAA battery
<b>Resolution</b>	Touch resolution is approximately 4096 x 4096.
<b>Screen Surface</b>	The hard laminate surface is puncture resistant and optimized for projection.
<b>Digitizing Technology</b>	DViT™ (Digital Vision Touch) technology uses two digital cameras to track the infrared pen tip across the display surface.
<b>Frame Finish</b>	Graphite grey frame and pen tray (approximates Pantone® 425 C) and Ultrasonic Chrome valance (approximates metallic Pantone 877 C)
<b>Wall-Mount Bracket</b>	32" (81.3 cm) wide with five screws and drywall anchors to support a wall-mounted interactive whiteboard.
<b>Computer Connection</b>	High speed connection via a 16' (5 m) USB 2.0 cable
<b>Power Requirements</b>	The computer provides power directly through the USB cable for Windows® computers. Power consumption is less than 2.5 W (500mA at 5V).
<b>Security</b>	Three Kensington® security slots
<b>Certifications and Compliance</b>	CE, RoHS (China), RoHS (Europe), WEEE
<b>Warranty</b>	Five-year limited equipment warranty upon registration. See warranty document for details.

**NOTE:** A projector is not included with this SMART Board interactive whiteboard model. To take advantage of all interactive features, you must integrate a projector.

---

## SMART Board Software Computer Requirements

<b>Windows Computers</b>	Intel® Pentium® 4, 2 GHz processor or faster (2.5 GHz processor recommended) 512 MB of RAM (1 GB recommended) 180 MB of free hard disk space for minimum installation (840 MB for full installation with Gallery collections) High speed, USB 2.0 compliant interface Driver update for USB Smart Card reader (requires an Internet connection to access the <a href="#">Microsoft® Update Catalog</a> ) Windows XP operating system Service Pack 2 (SP2) or later Updated USB Video Class (UVC) driver for Windows XP Service Pack 2 (SP2) (recommended). See Microsoft Corporation <a href="#">document 899271</a> . Internet Explorer® Internet browser 6.0 or later Adobe Flash™ player version 8
--------------------------	--

---

## Storage and Operating Specifications

<b>Storage</b>	-40°F to 120°F (-40°C to 50°C)
<b>Operation</b>	41°F to 95°F (5°C to 35°C) with up to 80% humidity non-condensing

---

## SMART Order Number

<b>SBV280</b>	77" (195.6 cm) diagonal SMART Board V280 interactive whiteboard
---------------	---

---

## Replacement Parts and Optional Accessories

<b>Part Number</b>	<b>Description</b>
<b>FRU-SB6WM</b>	SMART Board interactive whiteboard wall mounting kit (includes five screws and five drywall anchors)
<b>FSV280</b>	Mobile floor stand for SMART Board V280 interactive whiteboards

Dimensions

Wall Mounted  
Cut Away View

Leave at least 5/8" (1.6 cm) headroom to wall mount the SBV280

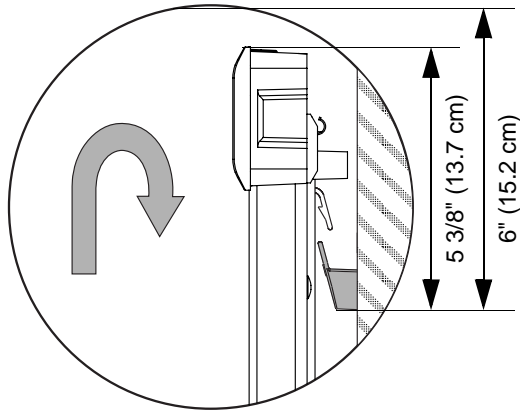

Wall Mounted  
Side View

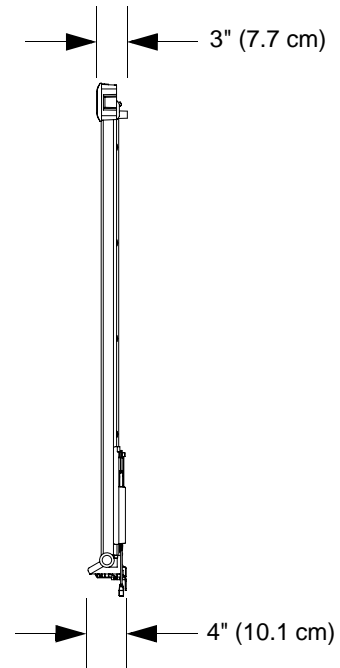

Wall Mounted  
Front View

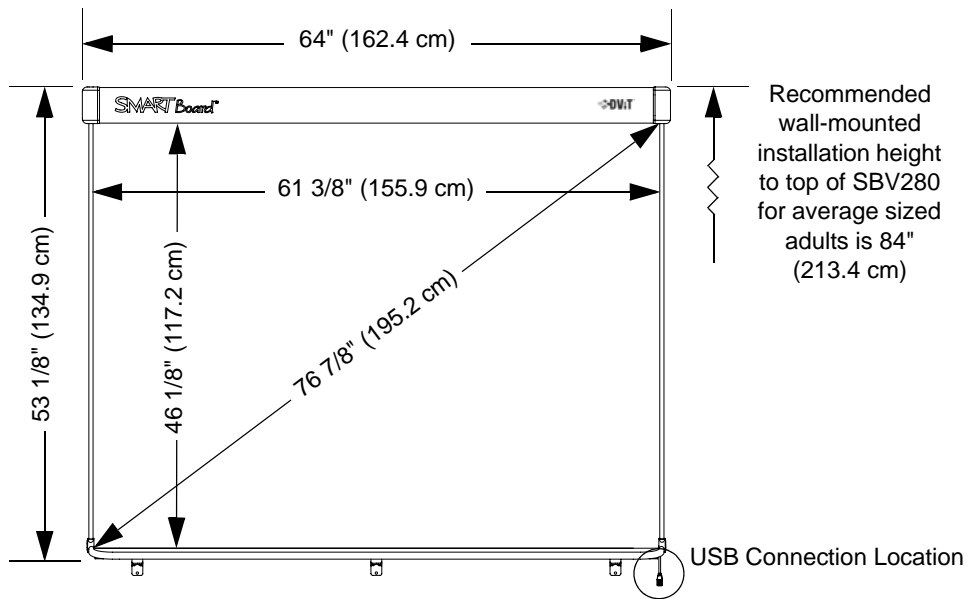

All dimensions +/- 1/8" (3.2 mm)